

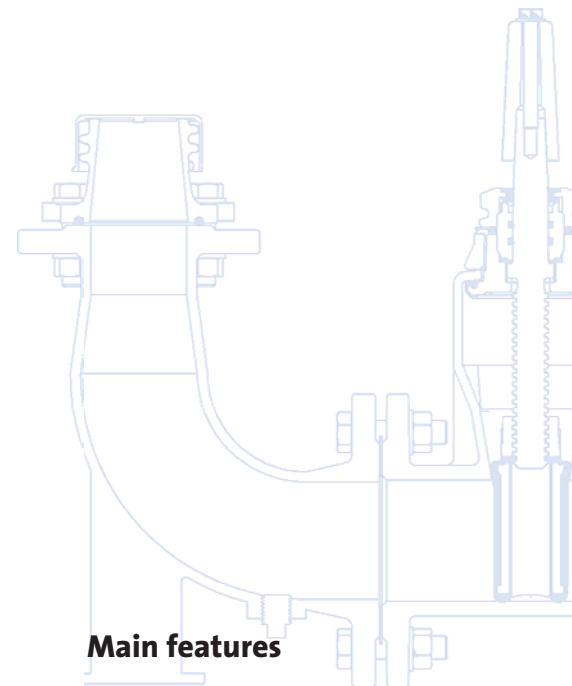

FH1 Fire Hydrant

DN80, PN16

FH1 Fire Hydrant to BS 750, Type 1 offers higher discharge rates than the FH2 version.



Main features

- Robust design with minimal maintenance requirements
- Utilises the PAM Gate Way gate valve
- Conforms totally to BS 750
- Ductile iron construction
- All non-metallic parts are WRAS approved
- Equipped with frost plug as standard
- 2 1/2" London round thread to BS 750:2006
- Blue fusion bonded epoxy coating in accordance with BS EN 14901

Technical Features

Technical information

- Fully compliant with requirements of BS EN 14339, BS EN 1074-6 and BS 750
- Maximum operating temperature 60°C
- Blue fusion bonded epoxy coating to BS EN 14901
- Flanges to BS EN 1092-2 PN16
- Weight 32kg
- Direction of closure clockwise as standard
- Stem seals and stem cap to BS 750:2006
- Drainage system
 - time to drain <10 minutes
 - water retained after draining <100ml
- MOT 140 Nm
- MST 700 Nm
- Kv 154
- Number of turns
 - to start flow <1
 - to fully open 7.5

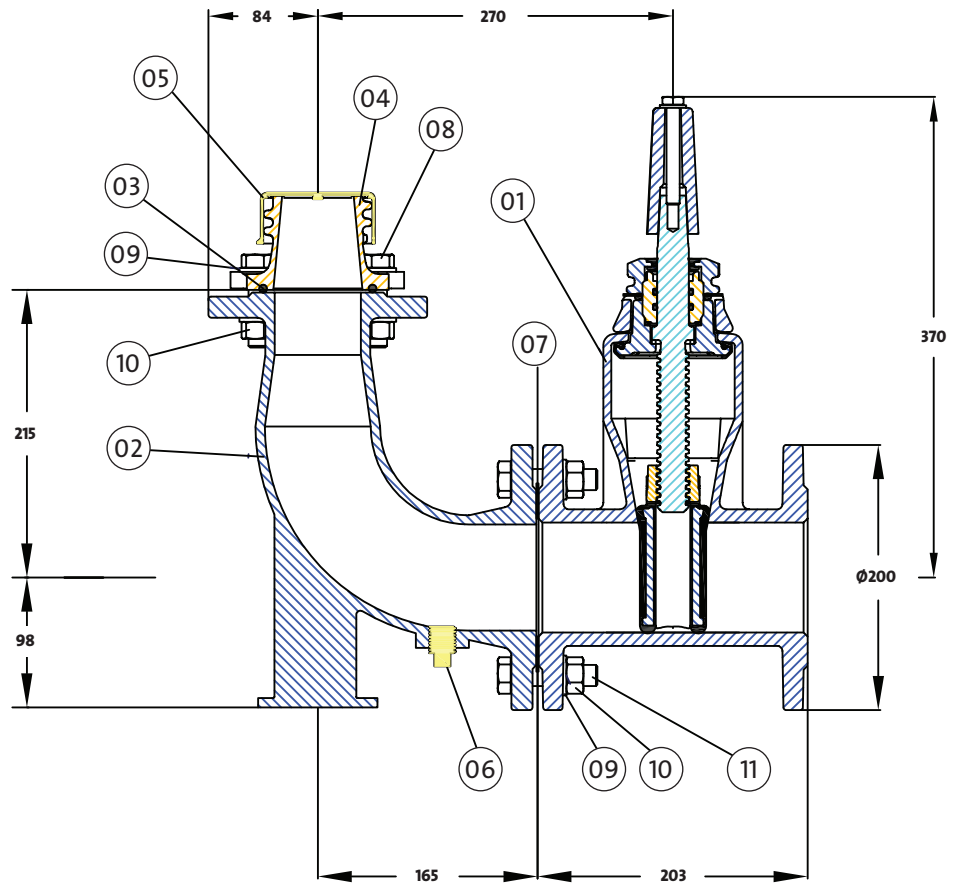

Dimensions in mm
Flanges in accordance with BS EN 1092-2

Materials

Item	Quantity	Description	Material
01	1	DN80 gate valve	Refer to PAM Gate Way data sheet
02	1	Duckfoot bend	Ductile iron Gr. 420/5
03	1	Outlet 'O' ring	EPDM
04	1	Outlet – 2 1/2" LRT	Stainless steel
05	1	Outlet cap	Polyethylene
06	1	Frost plug	Acetal/brass/steel
07	1	Flange gasket	EPDM
08	4	Hex – head bolt	Stainless steel Gr. A2-70
09	16	Washer	Stainless steel Gr. A2-70
10	12	Hex – nut	Stainless steel Gr. A2-70
11	8	Hex – head bolt	Stainless steel Gr. A2-70

Saint-Gobain PAM UK Ltd

Lows Lane, Stanton-by-Dale, Ilkeston, Derbyshire DE7 4QU
Tel: +44 (0)115 930 5000
Fax: +44 (0)115 932 9513
Website: www.saint-gobain-pam.co.uk

The information given in this leaflet is, to the best of our knowledge, correct at the time of going to press. However Saint-Gobain PAM UK are constantly looking at ways of improving their products and services and therefore reserve the right to change, without prior notice, any of the data contained in this leaflet. Please contact our Technical Sales Department for detailed advice.

© 2009 Saint-Gobain PAM UK



Cert. No. 12908